

DOOR SCHEDULE

DOOR NO.	DOOR SIZE	DOOR THK	DOOR TYPE	DOOR MATL.	FRM TYP	FRM MTL	GLAZING	FIRE RATING	HDW	NOTES
M2	PR 3'-0" x 8'-0"	1-3/4"	F6	ALUM	2	ALUM	TEMP/LAMINATED		I-2-1	IMPACT RESISTANT
NT	PR 3'-0" x 8'-0"	1-3/4"	F6	ALUM	2	ALUM	TEMP/LAMINATED		I-2-1	IMPACT RESISTANT
E1	3'-0" x 8'-0"	1-3/4"	F6	ALUM	2	ALUM	TEMP/LAMINATED		I-1-1	IMPACT RESISTANT
E4	PR 3'-0" x 8'-0"	1-3/4"	F6	ALUM	2	ALUM	TEMP/LAMINATED		I-2-1	IMPACT RESISTANT
M6	PR 3'-0" x 8'-0"	1-3/4"	F6	ALUM	2	ALUM	TEMP/LAMINATED		I-2-1	IMPACT RESISTANT/ DELETE CLOSER
E6-A	PR 2'-8" x 5'-0"	1-1/2"	F	FIBERGLASS	1	FIBER GLASS		C-LABEL 3/4 HOUR	I-2-1	IMPACT RESISTANT/ DELETE CLOSER
L-1	3'-0" x 7'-0"	1-3/4"	F	SCMD	1	HM			2-1-3	
L-2	3'-0" x 7'-0"	1-3/4"	F	SCMD	1	HM			2-1-5	
L-3	3'-0" x 7'-0"	1-3/4"	F	SCMD	1	HM			2-1-4	
L-4	2'-6" x 7'-0"	1-3/4"	F	SCMD	1	HM			2-1-5	
L-5	3'-0" x 7'-0"	1-3/4"	F	SCMD	1	HM			2-1-4	
L-6	PR 3'-0" x 7'-0"	1-3/4"	F6	ALUM	2	ALUM	TEMP/LAMINATED		I-2-1	IMPACT RESISTANT
L-7	PR 3'-0" x 7'-0"	1-3/4"	F6	ALUM	2	ALUM	TEMP/LAMINATED		I-2-1	IMPACT RESISTANT
L-8	PR 3'-0" x 7'-0"	1-3/4"	F6	ALUM	2	ALUM	TEMP/LAMINATED		I-2-1	IMPACT RESISTANT
L-4	3'-0" x 7'-0"	1-3/4"	F	SCMD	1	HM			2-1-1	

DOOR IS DESIGNATED BY THE ROOM THAT IT SWINGS INTO. THE FIRST DOOR IS LABELED 'A', THE SECOND 'B', ETC. EXTERIOR DOORS ARE DESIGNATED BY THE ROOM THEY SWING OUT OF.

FINISH SCHEDULE

ROOM NAME	FLOOR		BASE		N. WALL		E. WALL		S. WALL		W. WALL		CEILING		NOTES
	MATL	TYPE	MATL	TYPE	MATL	TYPE	MATL	TYPE	MATL	TYPE	MATL	TYPE	MATL	TYPE	
LOBBY	CT	CT	6"	6"	GMB	PTD	GMB	PTD	GMB	PTD	GMB	PTD	GMB	PTD	18" X 18" CERAMIC FIELD TILE
WOMEN	CT	CT	6"	6"	GMB	ERC	CT	18X18	GMB	ERC	GMB	ERC	GMB	PTD	FULL HEIGHT WALL TILE
MEN	CT	CT	6"	6"	GMB	ERC	GMB	ERC	GMB	ERC	CT	18X18	GMB	PTD	FULL HEIGHT WALL TILE
JANITOR	CT	CT	6"	6"	GMB	PTD	GMB	PTD	GMB	PTD	GMB	PTD	GMB	PTD	
ELEV. MACHINE	CT	CT	6"	6"	GMB	PTD	GMB	PTD	GMB	PTD	GMB	PTD	GMB	PTD	
LOUNGE	CT	CT	6"	6"	GMB	PTD	GMB	PTD	GMB	PTD	GMB	PTD	GMB	PTD	18" X 18" CERAMIC FIELD TILE
BAR	CT	CT	6"	6"	GMB	PTD	GMB	PTD	GMB	PTD	GMB	PTD	GMB	PTD	
STAIRWELL	VCT	R	4"	4"	GMB	PTD	GMB	PTD	GMB	PTD	GMB	PTD	GMB	PTD	PROVIDE NEW RESILIENT TILE TREADS

FINISH NOTES

1. PAINT ALL NEW AND EXISTING DOORS AND FRAMES ON ALL SIDES.
2. IN SMALL UNNUMBERED ROOMS SUCH AS CLOSETS, STORAGE AREAS AND NOOKS, EXTEND FLOOR, WALL AND CEILING FINISHES OF THE CONTIGUOUS SPACES INTO THESE AREAS.

DOOR TYPES:

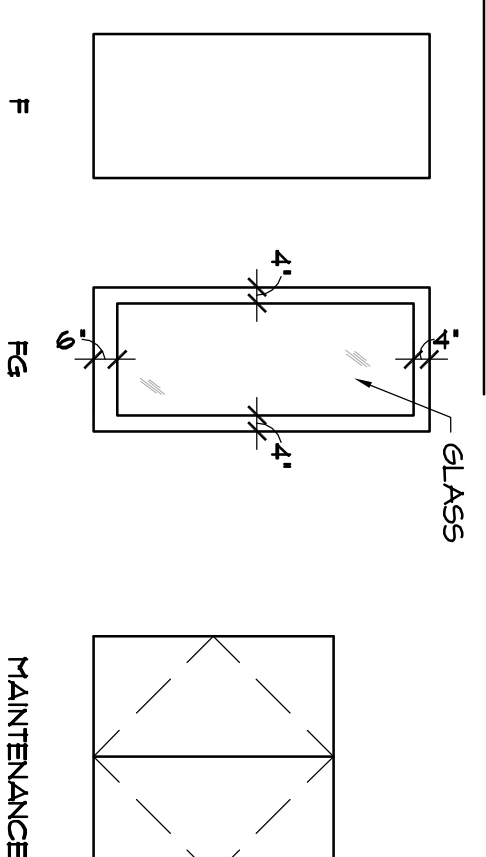

FRAME TYPES:

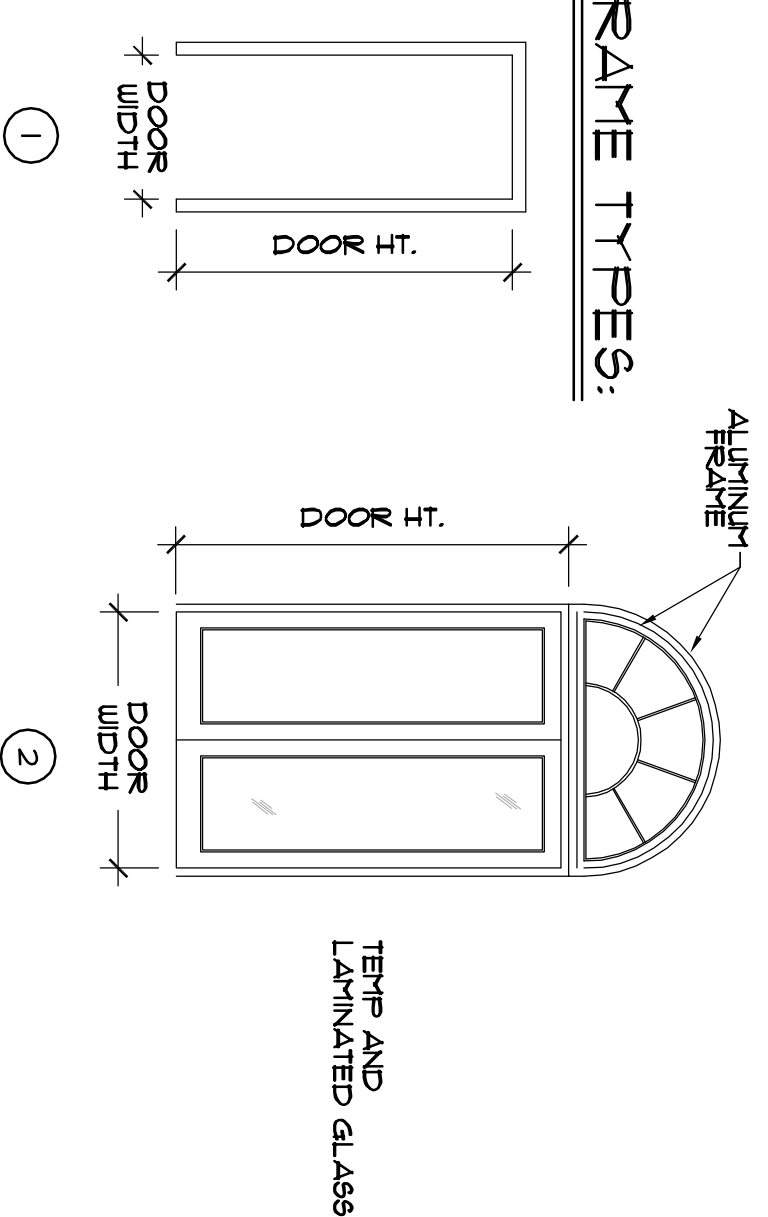

GENERAL DOOR AND HARDWARE NOTES:

1. ALL THRESHOLDS OF EXTERIOR DOORS SHALL BE NO MORE THAN 1/2" HIGH IN ACCORDANCE WITH THE FLOOR BUILDING CODE - CHAPTER 11, ON HANDICAPPED ACCESSIBILITY.
2. ALL EXTERIOR DOORS SHALL BE MANUFACTURED IN THESE ACCORDANCE WITH PRESSURES NOTED ELSEWHERE IN THESE DRAWINGS AND SHALL BE RATED NO LESS THAN THE REQUIREMENTS OF THE 1991 FEDERAL BUILDING CODE - CHAPTER 10, WEATHER RESISTANT BUILDING CODE - RESISTANT AND CAREY A HURTI-DADE COUNTY NDA OR EQUIVALENT.
3. ALL DOORS TO RECEIVE SILENCERS AND APPROPRIATE FLOOR OR WALL STOP.
4. SEE SPECIFICATIONS SECTION 081100 FOR HARDWARE DESCRIPTION.

HARDWARE SETS:

- EXTERIOR DOORS**
- 1-1-1 - 3 BUTT HINGERS
 - LOCKSET
 - THRESHOLD
 - WEATHERSTRIPPING
 - DOOR STOP
- INTERIOR DOORS**
- 2-1-3 - 3 BUTT HINGERS
 - 1 LOCKSET-ALWAYS OPENABLE FROM INT.
 - 2-1-4 - 3 BUTT HINGERS
 - SCREENED DOOR LATCHSET
 - 1-2-1 - 6 PR BUTT HINGERS
 - 1 LOCKSET-ALWAYS MANUVERABLE FROM INT.
 - 1 WEATHERSTRIP
 - 1 THRESHOLD
 - WEATHERSTRIPPING

FINISH MATERIALS:

- FLOOR**
- C - CARPET
 - 26 OZ LEVEL LOOP NYLON FIBER GLUE DOWN APPLICATION
 - VCT - VINYL COMPOSITION TILE
 - ARTSTRONG, IMPERIAL TEXTURE, 12X12 TILE, 1/8" THICK
 - CT - CERAMIC TILE
- BASE**
- R - RUBBER
 - TERCER, 1/8" RUBBERITE, 4" TALL w/ COVE BASE
 - CT - CERAMIC TILE
 - N - NONE
- WALL**
- P - PAINT
 - CT - CERAMIC TILE
 - N - NONE
 - ERC - EPOXY COATING

CEILING

- P - PAINT
- AP - ACOUSTICAL PANELS,
- 1. ARTISTRONG CORTEGA 24" x 24" x 5/8" REGULAR w/ WHITE PAINTED STEEL SUSPENSION SYSTEM
- 2. 2' x 2' CERAMIC BOARD
- GMB - GYPFAM WALL BOARD

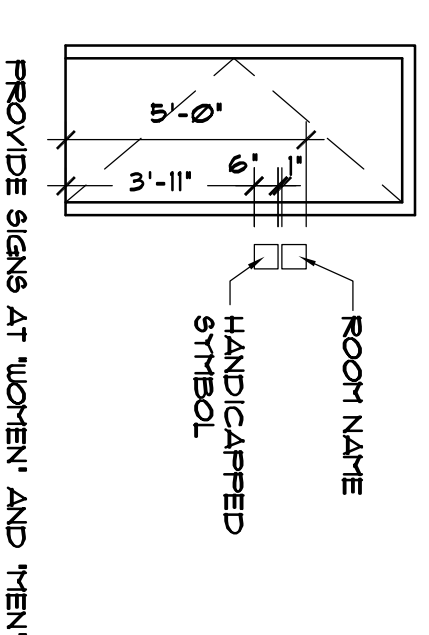

DOOR SIGNAGE DETAIL
SCALE: 1/4"=1'-0"

DESIGN, INC.
918 NORTH NOVA RD.
HOLLY HILL, FL 32117
AA 28000587
PHONE (386) 255-8987
FAX (386) 255-8989

REVISIONS	DATE

DAYTONA BEACH PIER BUILDING RENOVATION
MAIN STREET DAYTONA BEACH, FL

SCHEDULES
A6.1
SHEET

PUT#: 02126.11
DATE: 06/30/10
DRN BY: HRC
DGN BY: DHS
REV BY: DHS
SCALE: AS NOTED